

The NAUT324C is a 3-inch, 24V printer engine module with an integrated controller board and cutter, utilizing RS232 and USB communication ports.

It is suitable for a wide range of applications, including POS terminals, banking devices, measurement instruments, medical, and industrial equipment.



NAUT324C
closed door



NAUT324C
open door

GENERAL FEATURES

PERFORMANCE

- High print speed and resolution
- Highly reliable printing mechanism
- End of paper detection
- Full control over print quality/speed
- Powerful text and graphics printing modes

TECHNOLOGY

- Integrated cutter (easy to use system)
- Easy paper loading system
- Cover open/close detection
- Integrated electronic control board
- Easy firmware upgrade

PRINTING

- Barcode support (code 39, 128, QR etc.)
- Four resident character fonts, user defined fonts
- Easy upgrade of fonts, macros, logos

SAFETY

- Anti-jamming and damage prevention
- Printer status LED

MAIN APPLICATIONS



POS
terminals



Measurement
instrument



Banking
devices



Medical
equipment



Industrial
equipment



Cash
dispenser



Retail



Cash
deposit



Kiosk



Voting

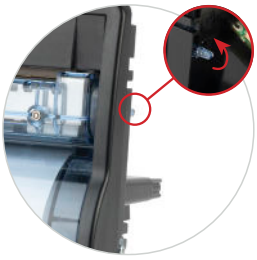

NAUT324C-BL
(Back side opening Lever)

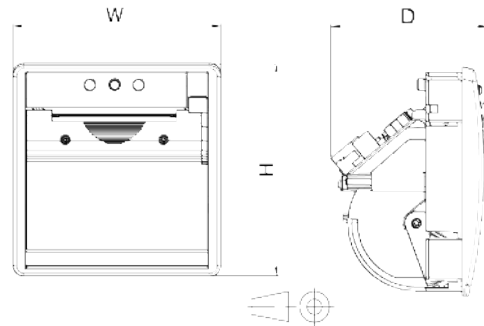

NAUT 324C
(Front side opening Lever)

Dimensions (W x H x D)
128.4 x 147.7 x 96.3 mm

Weight
370 g without paper roll

Connections
USB and RS232

PRINTER SPECIFICATIONS

Printing method	Direct thermal dot-line printing
Number of dots	576
Thermal head temperature detection	Thermistore
Printing resolution	203 DPI (8 dots/mm)
Heat element pitch	0.125 mm
Paper feed pitch	0.125 mm
Printing width	72 mm
Printing speed	Max. 100 mm/s
Operating temperature	From 0 to +50 °C
Operating humidity	From 20 to 85% RH (no condensation)
Storage temperature	From -40 to +80 °C
Storage humidity	From 10 to 90% RH (no condensation)
Voltage range	24 V ± 5%
Current consumption	Average 3.5 A Max. 7 A peak

PAPER SPECIFICATIONS

Type of paper	Thermal rolls, outside heat sensitive
Paper width	80 mm +0/-1
Paper weight	Min. 55 / Max.80 g/m2
Paper thickness	Min. 63 / Max. 80 µm
Paper roll outside diameter	Max. 83 mm
Roll core inner diameter	12.5 mm +1/-0
Core material	Plastic or cardboard
Paper end	Not attached to the roll core
Recommended paper	JUJO-AF50KS-E (standard grade, 55 g/m2)

CUTTER UNIT

Cutting method	Guillotine
Cut modes	Full and partial
Cut frequency	20 cuts/minute max.
Cut time	Max 500 ms

PRINTER LIFE SPECIFICATIONS

Print head pulse life	100 million pulses
Print head abrasion life	50 km of paper
Cutter life	Min. 500.000 cuts
Cover open/close	5.000 cycles or more

STANDARDS

Complies with:
 UL/IEC 62368-1 (UL-Recognized).
 FCC Title 47, Part 15, Subpart B.
 RoHS 2011/65/EU, 2015/863/EU and following amendments.
 CE 2014/30/EU, EN55032, EN55035.

CONNECTIONS

Phoenix MSTB 2.5/ 2-G-5.08 (Power)
 Standard USB Mini-B receptacle (USB Interface)
 Standard RJ25 6P6C (RS232 Interface)

DRIVERS

Windows 7 / 10 / 11
 Linux
 CE 6 / 7